

TOYOPEARL® HW Type

PACKING MANUAL





TOSOH CORPORATION

Safety Precautions

Before using the product, please read this manual thoroughly, to help protect your property from potential damage and ensure your own personal safety.

[Notational Conventions]

Notation	Meaning
 WARNING	Alerts the user to the potential for serious injury or death.
 CAUTION	Alerts the user to the potential for damage to hardware or bodily harm.

WARNING

■ **Keep away from fire.**

When using with flammable solvents, it can cause fire, explosion, or poisoning.

CAUTION

■ **Use only in well ventilated areas.**

In case of insufficient ventilation, flammable and toxic solvents can cause fire, explosion, or poisoning.

■ **Do not spill solvents.**

Spillage and leakage can cause fire, electric shorts, poisoning, injury, and corrosion. When cleaning up the spill, wear suitable protective equipment.

■ **Wear eye protection and protective globes.**

Organic solvents or acid is harmful in contact with skin.

■ **Handle package with care.**

Inappropriate handling may cause rupture and spattering.

■ **Do not use for unintended use.**

This product is for separation and purification, do not use for any other purpose.

■ **When packing the columns, keep appropriate pressure.**

Overpressure may cause rupture and spattering. Wear suitable protective equipments while packing.

■ **Make sure of the safety of the obtained compound and solution after separation and purification.**

■ **Dispose of in an authorised way.**

Dispose of in the conventional procedures in compliance with local, state and federal regulations.

NOTE

■ **Keep this manual with the product.**

— Contents —

1. Introduction	1
1-1. Cautions for packing TOYOPEARL HW gels	1
1-2. Columns	2
2. Removal of fines and preparation of gel slurry.....	3
2-1. Removal of fines.....	3
2-2. Preparation of gel slurry	4
3. Packing using a peristaltic pump.....	5
3-1. Constant-velocity packing method.....	5
3-2. Semi-constant pressure packing method	7
4. Gravitational packing	10
4-1. Packing method using a reservoir	10
4-2. Simplified packing method.....	12

1. Introduction

TOYOPEARL gels are packing materials developed to cover the intermediate region between dextran and other soft gels and the high performance liquid chromatography (HPLC) gels. Grain sizes, mechanical strength, and other basic property characteristics of TOYOPEARL are designed for this coverage. This also means that a wide variety of column packing methods, from the simplest gravitational packing to the pressure packing by pumping, are applicable to TOYOPEARL gels. In other words, TOYOPEARL gels are very easy to use.

This manual explains how to pack HW types of TOYOPEARL gels as some Cautions summarized as below have to be observed in preparing TOYOPEARL HW columns of high performance.

Table 1 gives relative advantages and disadvantages of various packing methods and necessary equipment, so that users may select whichever of them most suitable to prevailing situations.

1-1. Cautions for packing TOYOPEARL HW gels

- a It is best to pack TOYOPEARL HW by application of gentle pressure, from 0.05 to 0.5MPa, and this means that the packing method using a peristaltic pump is most desirable, although this is by no means an absolute necessity. However, as different from HPLC gels, TOYOPEARL HW shall not be packed under high pressure.
- s In the case of the simplest gravitational packing, the application of the gravitational head pressure however high will not crush TOYOPEARL HW and, rather, the performance of the column packed by applying a highest possible head pressure will be better. Also, to decrease the viscosity of the packing solvent by heating and increase the velocity of packing is very effective in shortening the packing time.
- d Presence of fines in the gel slurry may clog the filter, increase the applied pressure, and slow down the packing velocity. Be sure to remove fines from the gel slurry as completely as possible by decantation as described in 2.1.

Table 1 Comparison of packing methods

Items		Packing using peristaltic pump		Gravitational packing	
		1. Constant-velocity method	2. Semi-constant pressure method	3. Method using reservoir	4. Simplified method (heating)
Features	Packing Velocity	○ Fast	○ Faster than a	× Slow	× Slow than d
	Applicable nowrate	○ Up to high flowrate	○ Up to high flowrate	× Limited to low flowrate	× Limited to low flowrate
	Reproducibility	○ Good	○ Very good	○ Good	○ Good
Equipment	Pump	× Necessary	× Necessary	× Necessary	○ Not necessary
	Reservoir	× Necessary	× Necessary	× Necessary	○ Not necessary
	Pressure gage	△ Is better to use one.	× Necessary	○ Not necessary	○ Not necessary

○ : advantage × : disadvantage

1-2. Columns

- a Approximately 0.3MPa pressure-resistant columns are better but common glass columns are fully usable.
- s If the column diameter is too small, it may disturb separations. Do not use columns with I.D. smaller than 1.5 cm unless such use is an absolute necessity.

2. Removal of fines and preparation of gel slurry

2-1. Removal of fines

a Transfer 500mL of TOYOPEARL HW into a 3L beaker.

s Add distilled water to make up 2L, stir, and give a standing to settle down.

Note: The necessary standing time length differs with different grades (particle sizes) of TOYOPEARL HW and, in the case of HW-55 type, is as below:

Coarse grade : 15~30 min.

Fine grade : 30~45 min.

Super fine grade : 60~90 min.

d Discard the supernatant (containing fines) by decantation.

f Repeat s and d operations 3 or more times.

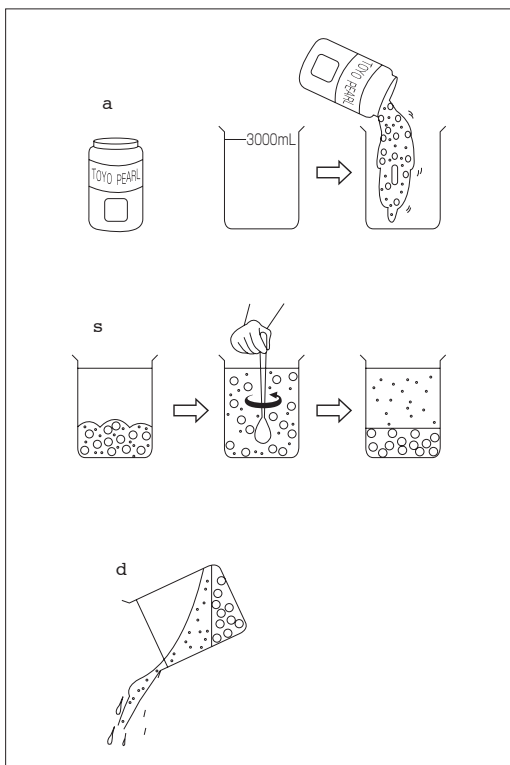

How to remove Fines

2-2. Preparation of gel slurry

- a After removing fines from the gel as above, wash the gel twice with the packing solvent of a volume 3 times the volume of the gel.
- s Using a measuring cylinder, measure out the washed gel of a volume 1.2 times the column volume.

Approximate volumes of the washed gel to be measured out for packing standard size columns are as below.

Column size cm (I.D) × cm (L)	Volume of gel mL
1.5 × 80	170
2.2 × 80	360
4.4 × 30	550
4.4 × 60	1100

- d By adding the packing solvent to the measured out gel, slurry the gel for a gel density of 30 to 50%.

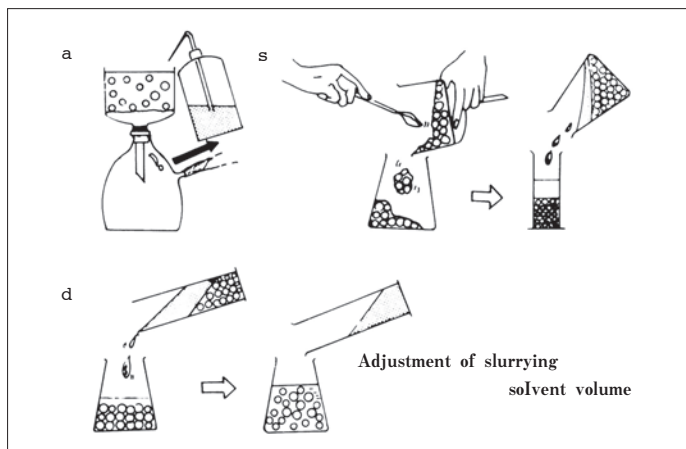

How to prepare gel slurry

3. Packing using a peristaltic pump

Packing conditions differ with different types and grades of TOYOPEARL HW.

3-1. Constant-velocity packing method

- Advantage : ·Packing velocity is high.
 ·Applications of up to high flowrate are possible.
- Disadvantage : ·A peristaltic pump is necessary.
 ·A reservoir is necessary.

Filling operation

- a Set up the apparatus as illustrated, and plug the bottom outlet of the column.

Note: The reservoir can be substituted with a extension column of glass tube which as a rule shall be longer than and of the same inner diameter as the column to be packed.

- s As illustrated, tighten the screw of the pump by turning to the clockwise extreme.
- d Switch on the pump and set the pump for a proper flowrate of packing solvent by turning the CONTROL knob.

Table 2 gives the range of proper flowrates of packing solvent for Fine grade gels.

Proper flowrates for Superfine grade gels are about one half of flowrates listed in the table, and those for Coarse grade gels are about two times as high as the listed flowrates.

Table 2 Packing solvent flowrates for TOYOPEARL HW gels

Grade	Column size cm(I.D)× cm(L)	Flowrate	
		Absolute velocity	Linear velocity
		mL/min	mL/h·cm ²
HW-40F	1.0×60	1.0~ 1.4	70~110
	1.6×60	2.4~ 3.0	70~ 90
	2.2×60	4.0~ 5.0	60~ 80
	4.4×60	10.0~14.0	40~ 60
HW-55F	1.6×60	2.0~ 3.0	60~ 85
HW-50F	3.2×60	6.0~ 9.0	45~ 65
HW-60F	4.4×60	1.0~ 6.0	45~ 65
	2.2×30	6.0~ 8.0	95~130
	2.2×45	4.0~ 6.0	65~ 90
	2.2×60	3.0~ 5.0	50~ 70
	2.2×90	2.4~ 3.0	35~ 55
HW-65F	2.2×60	2.5~10.0	40~150
HW-75F	2.2×60	2.5~10.0	40~150

- f After well stirring the gel slurry, carefully transfer it into the reservoir in one pouring.
- g Fill up the reservoir with packing solvent and cap the reservoir.
- h Connect the tube from the pump to the reservoir, switch on the pump, and quickly unplug the bottom outlet of the column. Continue pumping the solvent even if the velocity of flow slows down.
- j If the packing is not completed in the above described one operation, remove the supernatant and pack the column by pouring an additional volume of gel slurry into the reservoir. Equilibrate gel bed by flowing the eluent of a volume at least three times the gel bed volume.

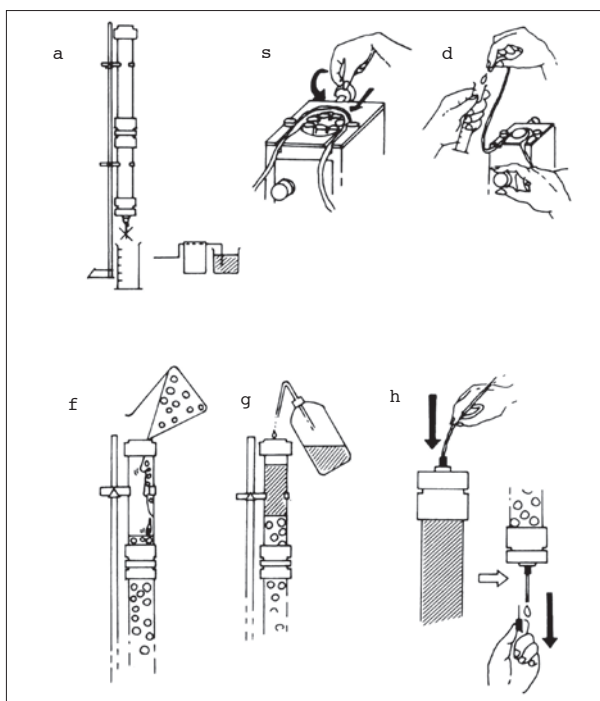

Constant-velocity packing method (filling operation)

After completion of filling operation

- a Plug the bottom outlet of the column.
- s Switch off the pump, and loosen the screw as illustrated.
- d Disconnect the tube of the pump from the reservoir

- f Discard the packing solvent remaining in the reservoir and detach the reservoir from the column. When doing this, be attentive so as not to discard the remnant of gel slurry in the reservoir together with the packing solvent.
- g Tighten the column cap and insert a blind plug.

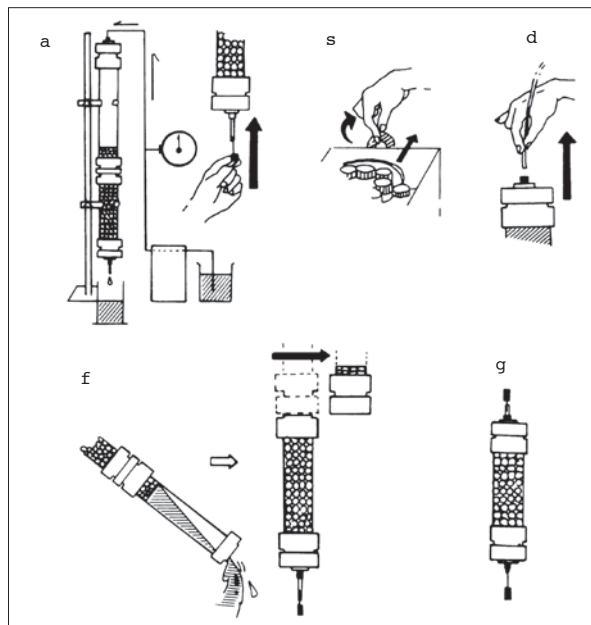

Constant-velocity packing method (after completion of filling operation)

3-2. Semi-constant pressure packing method

- Advantage :
- Packing velocity is faster than in the constant-velocity packing method.
 - Applications of up to high flowrate are possible.
 - Very good reproducibility of packing.
 - The range of proper flowrates is wide and less dependent on gel types.
- Disadvantage :
- A peristaltic pump is necessary.
 - A pressure gage is necessary.
 - A reservoir is necessary.

Filling operation

- a Set up the apparatus as illustrated, and plug the bottom outlet of the column.
- Note: The reservoir can be substituted with an extension column of glass tube which as a rule shall be longer than and of the same inner diameter as the column to be packed.
- s As illustrated, tighten up the screw of the peristaltic pump, and turn the CONTROL knob to MAX.
 - d After plugging the tube of the pump, switch on the pump.
 - f By gradually loosening the screw of the pump, adjust the delivery pressure between 0.15 and 0.20MPa.
 - g After well stirring the gel slurry, carefully transfer it into the reservoir in one pouring.
 - h Fill up the reservoir with packing solvent and cap the reservoir.
 - j Connect the tube of the pump to the reservoir, switch on the pump, and quickly unplug the bottom outlet of the column.
- Equilibrate the gel bed by flowing the eluent of a volume at least three times the gel bed volume.

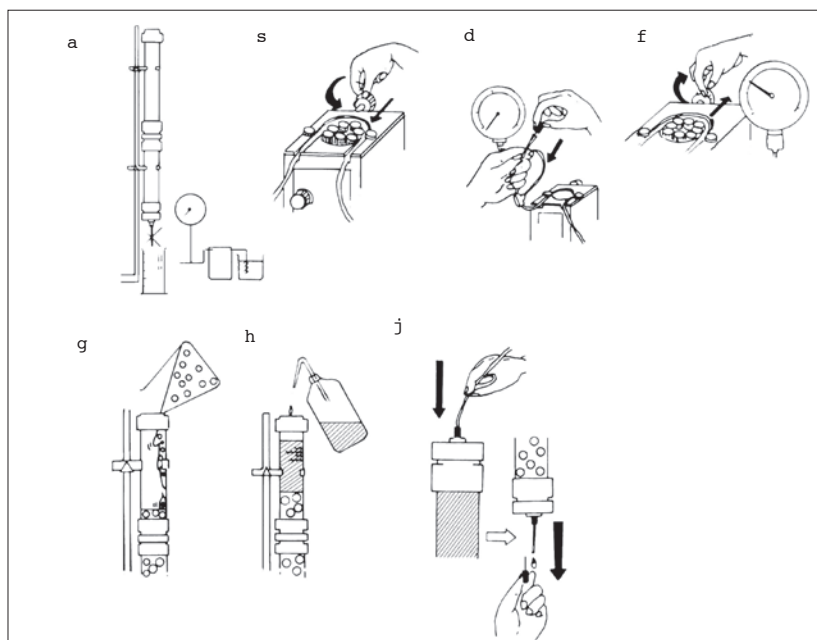

Semi-constant pressure packing method (filling operation)

After completion of filling operation

- a Plug the bottom outlet of the column.
- s Switch off the pump and, as illustrated, zero the pressure by turning screw to the counterclockwise extreme.
- d Disconnect the tube of the pump from the reservoir.
- f Discard the packing solvent remaining in the reservoir, and detach the reservoir from the column. When doing this, be attentive so as not to discard the remnant of gel slurry in the reservoir together with the packing solvent.
- g Tighten the column cap and insert a blind plug.

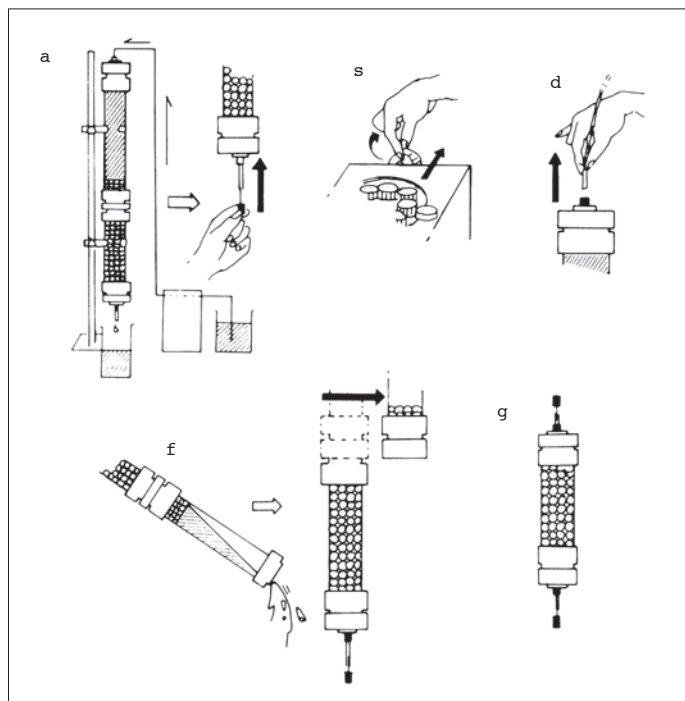

Semi-constant pressure packing method
(after completion of filling operation)

4. Gravitational packing

4-1. Packing method using a reservoir

Advantage : ·Pump is not necessary.

·Pressure gage is not necessary.

Disadvantage : ·Packing velocity is slow.

·The range of applicable flowrates is limited

Filling operation

a Set up the apparatus as illustrated, and plug the column outlet and the tube from the packing solvent tank.

Note: ·The higher the level of the solvent tank, the better will be the performance of the packed column.

·The reservoir can be substituted with an extension column which shall as rule be longer than and of the same inner diameter as the column to be packed.

s After well stirring the gel slurry, carefully transfer it into the reservoir in one pouring.

d Fill up the reservoir with packing solvent and cap the reservoir.

f Connect the tube from the solvent tank to the reservoir, and quickly unplug the outlet of the column.

Equilibrate the gel bed by flowing the eluent of a volume at least three times the gel bed volume.

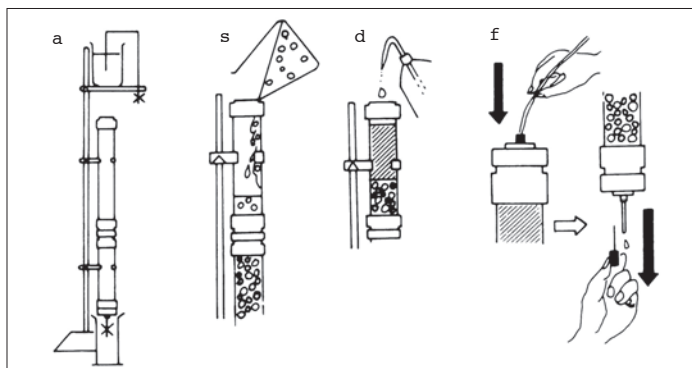

Gravitational packing using a reservoir
(filling operation)

After completion of filling operation

- a Plug the bottom outlet of the column.
- s Disconnect the tube of the solvent tank from the reservoir.
- d Discard the packing solvent remaining in the reservoir, and detach the reservoir from the column. In doing this, be attentive so as not to discard the remnant of gel slurry in the reservoir together with the solvent.
- f Tighten the column cap and plug the top and bottom ends of the column.

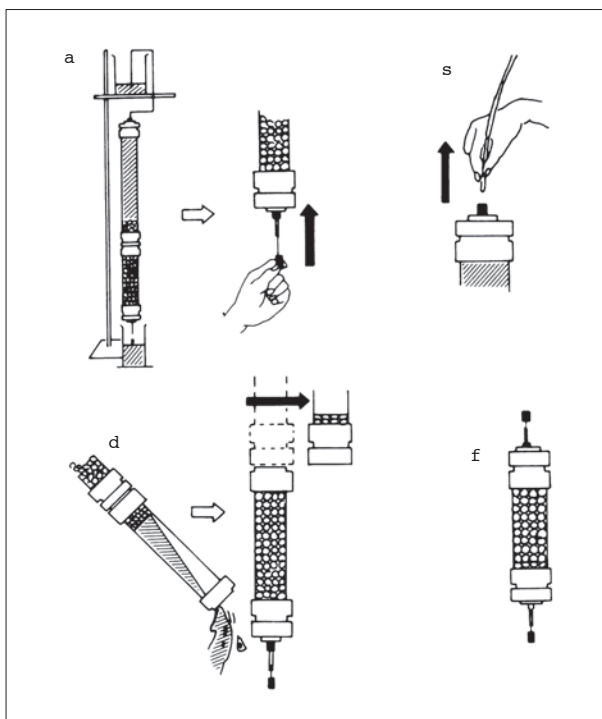

**Gravitational packing using a reservoir
(after completion of filling operation)**

4-2. Simplified packing method

Advantage : ·Pump is not necessary.

·Pressure gage is not necessary.

·Reservoir is not necessary.

Disadvantage : ·Velocity of packing operation is slow.

·The range of applicable flowrates is limited.

Filling operation

a Set up the apparatus as illustrated, and plug the column outlet.

Note: ·The higher the position of the funnel, the better will be the performance of the packed column.

·The glass tube I.D. shall be not less than 1.5cm and the length shall be the rubber stopper length plus 2~3cm.

s Pour the solvent, heated to 60° , into the funnel and fill up to the level above the neck A of the funnel.

d Unplug the column outlet and, when the level of the solvent drops to A, pour into the funnel the gel slurry which has been heated to 60° and well stirred.

f When the level of the poured-in gel slurry drops to A, start pouring of the packing solvent into the funnel.

Pour the solvent into the funnel in such a way that, until completion of the packing, the solvent level does not drop below A in the funnel, and equilibrate the gel bed by flowing the eluent of a volume about four times the gel bed volume.

Note: If during this filling operation the gel clogs the vinyl tube or the glass tube and slows down the flow of the packing solvent, withdraw the clogging gel and continue flowing the solvent.

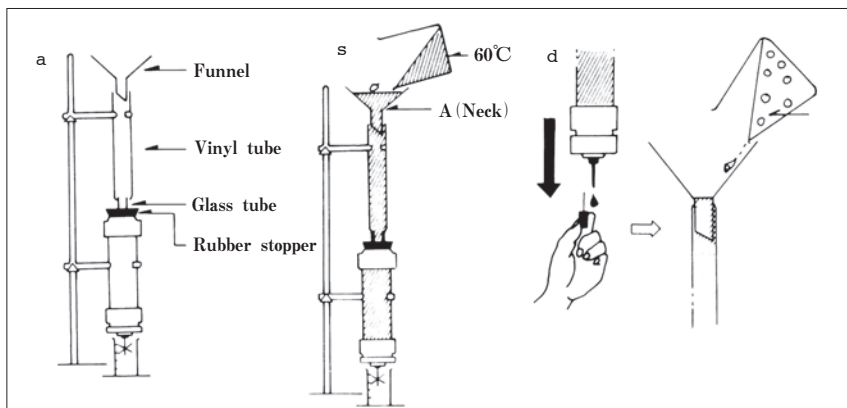

Simplified gravitational packing method (filling operation)

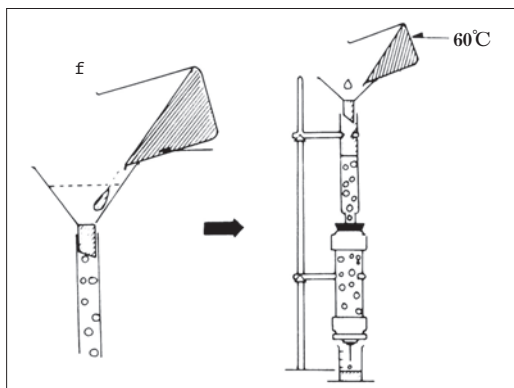

Simplified gravitational packing method
(filling operation)

After completion of filling operation

- a Plug the column end.
- s Detach the rubber stopper from the column, carefully so as not to let the gel remaining in the glass tube drop down.
- d Cap the column and plug the top.

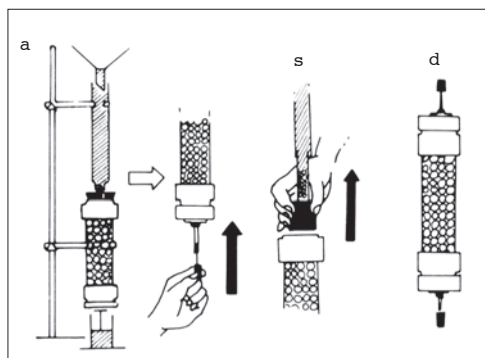

Simplified gravitational packing method
(after completion of filling operation)

The smaller the grain size, the better is the separatory power of gel, as below.

Superfine grade is recommendable for analytic separation.

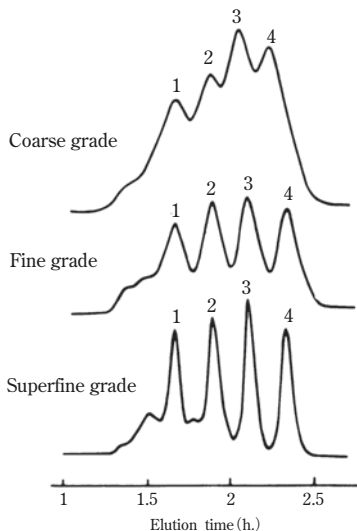

**Comparison of separatory powers of gels
of difference grain sizes**

Gel	: TOYOPEARL HW-55
Gel bed	: 2.6cm×70cm
Eluent	: 1/30mol/L phosphate buffer containing 0.2mol/L NaCl (pH7.0)
Flowrate	: 106mL/h (20mL/h·cm ²)
Temperature	: 25;
Sample	: 1mL
	1. Thyroglobulin (0.3%) M. W 670×10 ³
	2. γ -globulin (0.3%) M. W 160×10 ³
	3. β -lactoglobulin (0.3%) M. W 37×10 ³
	4. Cytochrome-C (0.1%) M. W 12×10 ³
Detection	: UV 280nm

MEMO



TOSOH

TOSOH CORPORATION

BIOSCIENCE DIVISION

Shiba-Koen First Bldg.

3-8-2 Shiba, Minato-ku, Tokyo 105-8623, Japan

Phone: +81-3-5427-5180 Fax: +81-3-5427-5220

Web site: <http://www.separations.asia.tosohbioscience.com/>

HPLC database: www2.tosoh.co.jp/hlc/hlcdb.nsf/StartE?OpenForm

TOSOH BIOSCIENCE LLC

3604 Horizon Drive Suite 100,
King of Prussia, PA 19406, USA

Phone: +1-800-366-4875 Fax: +1-610-272-3028

E-mail: info.tbl@tosoh.com

Web site: <http://www.tosohbioscience.com/>

TOSOH BIOSCIENCE GmbH

Zettachring 6, 70567 Stuttgart, Germany

Phone: +49-711-132570 Fax: +49-711-1325789

E-mail: info.tbg@tosoh.com

Web site: <http://www.tosohbioscience.com/>

TOSOH BIOSCIENCE SHANGHAI CO., LTD.

Room 301, Plaza B, No.1289 Yi Shan Road,
Xu Hui District, Shanghai 200233, China

Phone: +86-21-3461-0856 Fax: +86-21-3461-0858

E-mail: info@tosoh.com.cn

Web site: <http://www.separations.asia.tosohbioscience.com/>

TOSOH ASIA PTE. LTD.

63 Market Street #10-03 Singapore 048942

Phone: +65-6226-5106 Fax: +65-6226-5215

E-mail: info.tsas@tosoh.com

Web site: <http://www.separations.asia.tosohbioscience.com/>

HLC, TSK-GEL, TSKgel, TSKgel SuperMultipore, BioAssist, Enantio, PStQuick, Enviropak, TOYOPEARL, ToyoScreen, TOYOPEARL GigaCap, TOYOPEARL MegaCap, TOYOPEARLPAK and TOYOPAK are registered trademarks of TOSOH CORPORATION in Japan and other countries.

This manual may not be reprinted or copied in whole or in part without written consent of TOSOH CORPORATION. The contents of the manual are subject to change without notice.

Printed in Japan