

P0303903

Packed Columns
for TOYOPEARL® Screening

ToyoScreen® Series

INSTRUCTION MANUAL





TOSOH

TOSOH CORPORATION

Safety Precautions

To help protect you and/or your property from potential damage and ensure personal safety, please read this manual thoroughly before using the product.

[Notational Conventions]

Notation	Explanation
 WARNING	Indicates a hazard with a medium level of risk which, if not avoided, could result in death or serious injury.
 CAUTION	Indicates a hazard with a low level of risk which, if not avoided, could result in minor or moderate injury.

WARNING

■ **Keep away from fire**

Not taking proper precautions when using flammable solvents could result in fire, explosion, or poisoning.

CAUTION

■ **Use only in well-ventilated areas**

In case of insufficient ventilation, flammable and toxic solvents can cause fire, explosion, or poisoning.

■ **Do not spill solvents**

Spillage and leakage can cause fire, electric shock, poisoning, injury, or corrosion. Wear appropriate protective gear when cleaning up a spill.

■ **Wear protective eye gear and gloves**

Organic solvents and acids should not come into direct contact with the skin.

■ **Handle the package with care**

Inappropriate handling may cause rupturing and/or splattering of the product.

■ **Only use this product for its intended use**

This product is intended for the separation and purification of small molecules and proteins. Do not use it for any other purpose.

■ **Monitor the backpressure**

The maximum pressure of the column hardware is 1 MPa. Make sure the backpressure does not exceed the maximum.

■ **Make sure compounds are safe**

Check that the target compounds and solutions after separation and purification are safe.

■ **Proper disposal**

Dispose in accordance with local laws and regulations.

NOTE

Keep this manual with the product for future reference.

Precautions: Shipping Solvents

First Aid	Inhalation	<ul style="list-style-type: none"> • Move the person to an area with fresh air and rinse the mouth with plenty of water. ^{a) b) c)} • Call immediately for medical attention. ^{a)}
	Skin exposure	<ul style="list-style-type: none"> • Wash the exposed area with plenty of soap and water.
	Eye exposure	<ul style="list-style-type: none"> • Open the eyes as wide as possible and rinse with clean water for at least 15 minutes. • Call immediately for medical attention.
	Ingestion	<ul style="list-style-type: none"> • Rinse the mouth with plenty of water. • Call immediately for medical attention.
Handling and Storage	Ventilation	<ul style="list-style-type: none"> • Provide adequate air ventilation to keep organic vapor concentrations below approved level. ^{a)}
	Container handling	<ul style="list-style-type: none"> • Container may break if not handled with care. ^{a)}
	Wear appropriate protective equipment	<ul style="list-style-type: none"> • Use solvent-resistant gloves and protective eye gear when using this product. Use of a gas mask, additional protective clothing or rubber boots could be appropriate when handling this product. ^{a)} • Use rubber gloves and protective eye gear when using this product. ^{b) c)}
	Hazardous substance storage	<ul style="list-style-type: none"> • If any flammable solvents are used for shipping or storage of this product, keep away from fire and open heat sources. ^{a)}
	Storage temperature	<ul style="list-style-type: none"> • Avoid storing this product at very low temperatures ($< 0^{\circ}\text{C}$) to prevent product from freezing.
Waste Disposal	Disposal methods	<ul style="list-style-type: none"> • Dispose in accordance with local laws and regulations. ^{a)}
	General considerations	<ul style="list-style-type: none"> • Please pay attention to all safety precautions with respect to the handling and storage of this product.
<p>Note ^{a)} Shipping solvent; aqueous solution containing 20 % ethanol ToyoScreen DEAE-650M, ToyoScreen SuperQ-650M, ToyoScreen QAE-550C, ToyoScreen GigaCap Q-650M, ToyoScreen Q-600C AR, ToyoScreen GigaCap DEAE-650M, ToyoScreen CM-650M, ToyoScreen GigaCap CM-650M, ToyoScreen SP-650M, ToyoScreen SP-550C, ToyoScreen MegaCap II SP-550EC, ToyoScreen GigaCap S-650M, ToyoScreen AF-Chelate-650M, ToyoScreen AF-Blue HC-650M, ToyoScreen AF-Red-650M, ToyoScreen AF-Heparin HC-650M, ToyoScreen AF-rProtein A-650F, ToyoScreen AF-rProtein A HC-650F, ToyoScreen MX-Trp-650M</p> <p>^{b)} Shipping solvent; 1.8 mol/L ammonium sulfate ToyoScreen Ether-650M, ToyoScreen Phenyl-650M, ToyoScreen Butyl-650M, ToyoScreen Hexyl-650C, ToyoScreen PPG-600M, ToyoScreen Butyl-600M, ToyoScreen SuperButyl-550C</p> <p>^{c)} Shipping solvent; 3.6 mol/L ammonium sulfate ToyoScreen Phenyl-600M</p>		

Precautions: ToyoScreen Chromatographic Column

First Aid	Inhalation	<ul style="list-style-type: none"> • Move the person to an area with fresh air and rinse the mouth with plenty of water. • Call immediately for medical attention.
	Skin exposure	<ul style="list-style-type: none"> • Wash the exposed area with plenty of soap and water.
	Eye exposure	<ul style="list-style-type: none"> • Open the eyes as wide as possible and rinse with clean water for at least 15 minutes. • Call immediately for medical attention.
	Ingestion	<ul style="list-style-type: none"> • Rinse the mouth with plenty of water. • Call immediately for medical attention.
Handling and Storage	Ventilation	<ul style="list-style-type: none"> • Provide adequate air ventilation to keep organic vapor concentrations below approved level.
	Wear appropriate protective equipment	<ul style="list-style-type: none"> • Use solvent-resistant gloves and protective eye gear when using this product. Use of a dust respirator could be appropriate when handling dried chromatographic media.
	Hazardous substance storage	<ul style="list-style-type: none"> • If any flammable solvents are used for shipping or storage of this product, keep away from fire or open heat sources.
	Fire precautions	<ul style="list-style-type: none"> • Do not expose this chromatographic resin to fire or open heat sources.
Waste Disposal	Disposal methods	<ul style="list-style-type: none"> • Dispose in accordance with local laws and regulations. See below for additional precautions.
	General considerations	<ul style="list-style-type: none"> • Please pay attention to all safety precautions with respect to the handling and storage of this product.
	Disposal precaution	<ul style="list-style-type: none"> • This product can be safely incinerated. • Appropriate nitrogen oxides exhaust emission precautions should be taken specifically for ToyoScreen DEAE-650M, ToyoScreen SuperQ-650M, ToyoScreen QAE-550C, ToyoScreen GigaCap Q-650M, ToyoScreen Q-600C AR, ToyoScreen GigaCap DEAE-650M, ToyoScreen AF-Chelate-650M, ToyoScreen AF-Heparin HC-650M and ToyoScreen MX-Trp-650M. • Appropriate sulfur exhaust emission precautions should be taken specifically for ToyoScreen SP-650M, ToyoScreen SP-550C, ToyoScreen GigaCap S-650M and ToyoScreen MegaCap II SP-550EC. • Appropriate sulfur and nitrogen oxides exhaust emission precautions should be taken specifically for ToyoScreen AF-Red-650M, ToyoScreen AF-Blue HC-650M, ToyoScreen AF-rProtein A-650F and ToyoScreen AF-rProtein A HC-650F.
Note ToyoScreen products contain combustible packings based on a methacrylate polymer.		

Table of Contents

1. Introduction	1
2. Column Dimensions and Basic Properties of Packing Material	1
3. Column Components	2
4. Column Attachment	2
5. Connecting ToyoScreen Columns to an Instrument	4
6. Mobile Phases	5
7. Analytical Conditions	6
8. Storage	6
9. Remarks	8
10. Warranty	8

1. Introduction

The ToyoScreen Series consist of small pre-packed screening columns containing TOYOPEARL a media for semi-preparative and preparative liquid chromatography. These columns are suitable for evaluating different TOYOPEARL resins or for identifying purification conditions for biological target molecules such as proteins or nucleic acids.

2. Column Dimensions and Basic Properties of Packing Material

The ToyoScreen Series are available in two column volumes; 1 mL and 5 mL formats. The two different column sizes can be used in the following way:

Column volume	(inside diameter) × (length)	Purpose
1 mL column	6.4 mm × 3 cm	Selection of TOYOPEARL Preliminary evaluation of purity and recovery Purification of small amounts of sample
5 mL column	14.6 mm × 3 cm	Selection of TOYOPEARL Preliminary evaluation of purity and recovery Detailed evaluation of purification conditions Purification of small amounts of sample * Sample dynamic capacities should be evaluated using a minimum column length of 7.5 cm.

ToyoScreen columns contain TOYOPEARL resins for ion exchange chromatography (IEC), hydrophobic interaction chromatography (HIC), affinity chromatography (AFC) and Mixed-mode chromatography (MX).

IEC type	HIC type	AFC type	MX type
DEAE-650M	Ether-650M	AF-Chelate-650M	MX-Trp-650M
SuperQ-650M	Phenyl-650M	AF-Blue HC-650M	
GigaCap Q-650M	Butyl-650M	AF-Red-650M	
QAE-550C	Hexyl-650C	AF-Heparin HC-650M	
Q-600C AR	PPG-600M	AF-rProtein A-650F	
CM-650M	Phenyl-600M	AF-rProtein A HC-650F	
GigaCap DEAE-650M	Butyl-600M		
GigaCap CM-650M	SuperButyl-550C		
SP-650M			
SP-550C			
MegaCap II SP-550EC			
GigaCap S-650M			

3. Column Components

The column housing is essentially a syringe barrel that is filled with the packing material sandwiched between two frits.

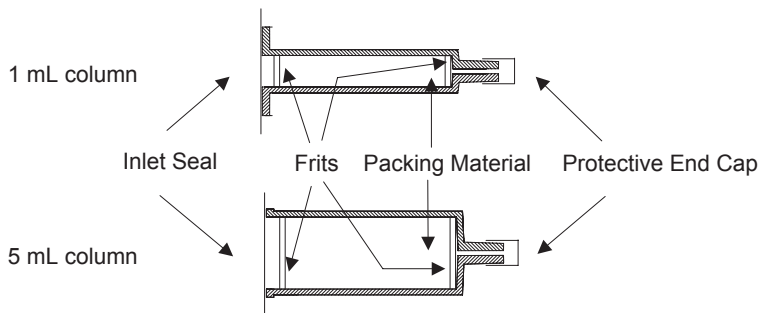

ToyoScreen must be used with the custom designed holder (ToyoScreen Holder: Part No. 0021400), which is sold separately. The holder consists of the following components:

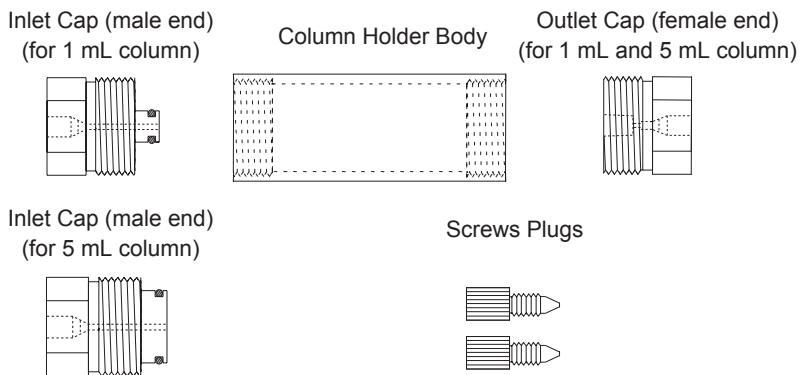

4. Column Attachment

Insert the column into the holder according to the procedure described below. Care should be taken to avoid applying any pressure across the frit while placing the column inside the holder. Applying pressure across the frit may lower column performance. Please note: the final upper frit position is not determined until the column is properly placed into the holder.

- 1) Carefully peel the foil seal (A) from the column. Make sure that all foil is removed or column performance may be decreased. Do not remove Protective End Cap

(D). Place the plastic Inlet Cap (B) on top of the column and slowly insert the male end of the Inlet Cap (B) into the column housing. It is important to remember that when attaching the Inlet Cap (B) to the column, leave the flow hole of the Inlet Cap open (C). If the Protective End Cap (D) was removed by mistake, block the column outlet using your finger (with solvent resistant rubber gloves) or by some other means to avoid air from entering the column. Please note that the ToyoScreen device may leak if the male end of the holder is attached with too much force.

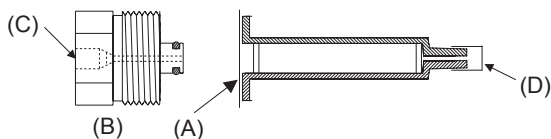

2) Attach a Screw plug (E) to the Inlet Cap (B) as shown below. Carefully remove the Protective End Cap (D) at the bottom of the column and slowly hand-tighten the column into the Column Holder Body. **DO NOT USE A WRENCH TO TIGHTEN THE HOLDER.**

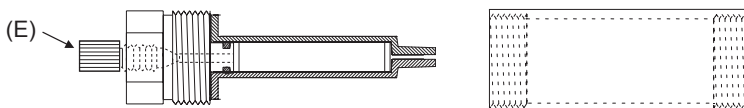

3) Slowly hand-tighten the plastic Outlet Cap (F) into the Column Holder Body making sure that the outlet hole aligns with the bottom of the column. **DO NOT USE A WRENCH TO TIGHTEN THE HOLDER.**

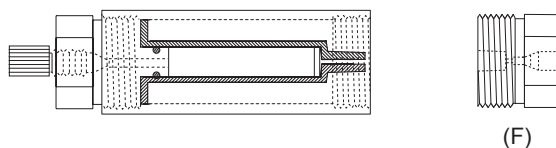

4) Remove the Screw plug (E) and connect the column to the liquid chromatographic system according to section 5 below.

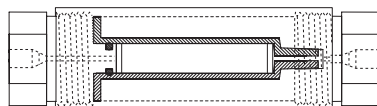

5. Connecting ToyoScreen Columns to an Instrument

5-1 Fittings

The column should be attached to the injector and detector using 1/16" tubing. Narrow internal diameter PEEK (polyetheretherketone) or plastic tubing is recommended to prevent sample dilution. Metal fittings may damage the column, therefore plastic or PEEK fittings should be used to attach tubing to the ToyoScreen columns. The PEEK fittings are sold separately (Part No. 0016566).

When using an FPLC system, a T-F union should be used (sold separately, Part No. 0020028).

Note FPLC is a registered trademark of GE Healthcare.

5-2 Flow Direction

The mobile phase should only flow through the column in the direction indicated on the label.

5-3 Prevent Air from Entering the Column

When attaching or detaching the column from the instrument, take great care to prevent air from entering the column. Flush all air bubbles from the tubing using mobile phase before attaching the column to the instrument. Air bubbles introduced onto the column may result in uneven flow (channeling) and lower performance.

5-4 Connection to Instrument

Prior to connecting the column, connect two pieces of tubing (one piece to connect the column to the injector, the other connecting the column to the detector) with a 1/16" union, and pump mobile phase through the tubing in order to expel the air from the column inlet tubing.

The next step is to remove any air, if present, from the column. Connect the outlet end of the column to the injector or pump and slowly pump *in the reverse direction*, mobile phase through the column to expel any remaining air bubbles. It is important to prevent a sudden surge of mobile phase or pressure as this may lower the performance of the column. Therefore, slowly step-up the mobile phase flow rate until it reaches the desired value (we recommend 1 mL/min for the 1 mL columns and 5 mL/min for 5 mL columns). After confirming that there are no bubbles eluting from the inlet (top) of the column, stop the flow and disconnect the column. Reposition the column in the direction of the flow arrow and carefully reconnect the top of the column to the injector/pump. Please note that if a detector is connected, the column backpressure may increase significantly due to resistance of tubing inside the detector. In this case, either replace the tubing causing the higher pressure or lower the flow rate.

5-5 Prior to Analysis

After the column is properly installed between the injector and detector, avoid sudden pressurization by slowly stepping-up the flow rate of the mobile phase until the desired flow rate is obtained (see section 7; for flow rate guidelines).

5-6 Post Analysis

After operation, do not detach the column from the instrument until the pump stops and the flow of the mobile phase has stopped. If the column is detached before the flow has stopped, the column will be subjected to a sudden pressure drop that may cause the performance to deteriorate.

6. Mobile Phases

6-1 Mobile Phase Viscosity

When using a highly viscous mobile phase, such as mixtures of organics with aqueous buffer, use a lower flow rate because the backpressure increases with viscosity of the mobile phase. High backpressure may damage the column.

6-2 Impurities in Mobile Phase

In order to prevent ghost peaks, analytical grade solvents are recommended.

6-3 Dissolution of Sample

Select a solvent that completely dissolves the sample. If there is precipitate in the injected sample, the inlet tubing and/or inlet frit may become plugged resulting in lower performance.

6-4 Degassing

If the mobile phase is not adequately degassed, bubbles may enter the column and decrease column performance. To prevent this problem, degas the mobile phase thoroughly. If only a few bubbles are present in the column, performance may be recovered by running a well-degassed mobile phase (such as distilled water) through the column.

7. Analytical Conditions

7-1 Flow Rate

The operational flow rate is selected by considering the resolution, measurement time, and column life. As flow rate increases, analysis times decrease but a column void can develop more readily. Recommended flow rates are as follows:

Column volume	Recommended flow rate	Maximum flow rate
1 mL column	0.2 to 1 mL/min	4 mL/min
5 mL column	1 to 5 mL/min	20 mL/min

These flow rates are based on the viscosity of distilled water at 25 °C. Use proportionally lower flow rates when using a more viscous mobile phase.

7-2 Gradient Profile

Stepwise or linear gradient elution methods are effective for protein separation. A linear gradient profile significantly influences the separation efficiency. In general, shallower gradients result in higher resolution at the expense of longer run times. Conversely, steeper gradients result in shorter run times and lower resolution. Typical gradient volumes are 10-30 column volumes (IEC; 0 → 0.5 mol/L sodium chloride, HIC; 1.0 → 0 mol/L ammonium sulfate).

7-3 Sample Loading

Excess sample loading generally results in lower resolution. About 0.5 mg protein loading (*) or less for each 1 mL of column volume is recommended for optimum resolution.

(*This value is an approximation, because loading capacity is dependent on sample properties, analytical conditions, etc.)

8. Storage

We recommend that, after use, the column is washed with water and stored in 20 % aqueous ethanol (IEC type, AFC type and MX type) or 1.8 mol/L ammonium sulfate (HIC type). The screw plugs should be hand-tightened and the column should be stored at the temperature indicated on the label and protected from exposure to direct sunlight. When removing the column from the holder, the column can be sealed with the outlet cap in order to prevent the column from drying out. The procedure is described below (Please refer to the illustration on next page.).

- 1) Remove the screw plug located at the top of the column, leaving the bottom screw plug in place. Fill the inlet of the Inlet Cap with distilled water (G) and then slowly remove the Inlet Cap (H) from the holder.
- 2) Loosen the Outlet Cap of the holder, and detach the column from the Column Holder Body.
- 3) Fill the column top with water. Confirm that liquid drops exit from the bottom of the column through gravity flow and that no air bubbles are present in the column outlet (I).
- 4) Fill Protective End Cap (J) with water using a wash bottle or other suitable device and attach the cap to the column outlet side.
- 5) Attach the custom snap-on Seal Cap (K) to top of the column.

Keep the packing material from drying out according to the procedure described above. Drying the packing material can cause significant deterioration of column performance.

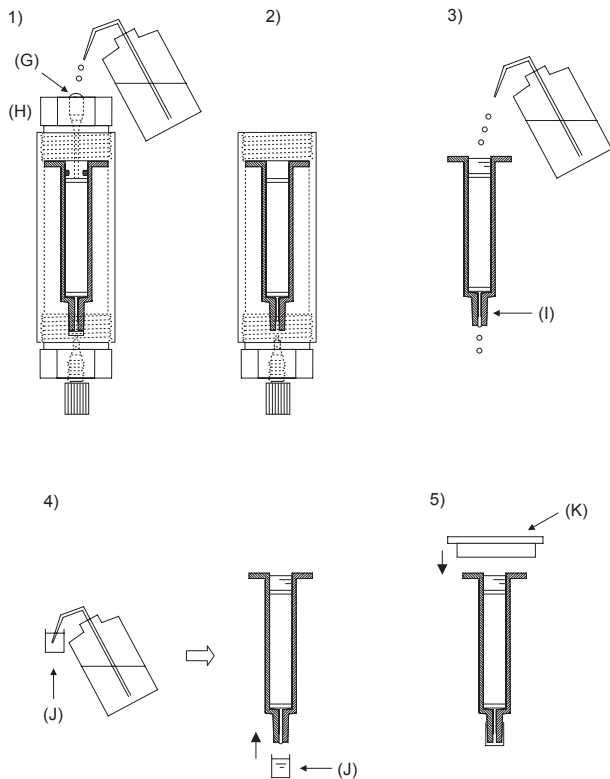

9. Remarks

ToyoScreen MX-Trp-650M should be kept away from oxidizing agent, protected from light and stored in the dark.

10. Warranty

- 1) Inspect the following immediately after receiving the product:
 - a. product package for any signs of damage.
 - b. each of the columns if it has not been dried.
- 2) If you should find any of the above defects, contact the local Tosoh sales representative within 2 weeks after receiving the product. After two weeks, we will assume that you have received a satisfactory product.

Product List of ToyoScreen Series

Part No.	Product Description	Package
0021360	ToyoScreen DEAE-650M	1 mL × 6 each
0021361	ToyoScreen DEAE-650M	5 mL × 6 each
0021362	ToyoScreen SuperQ-650M	1 mL × 6 each
0021363	ToyoScreen SuperQ-650M	5 mL × 6 each
0021364	ToyoScreen QAE-550C	1 mL × 6 each
0021365	ToyoScreen QAE-550C	5 mL × 6 each
0021859	ToyoScreen GigaCap Q-650M	1 mL × 6 each
0021860	ToyoScreen GigaCap Q-650M	5 mL × 6 each
0021992	ToyoScreen Q-600C AR	1 mL × 6 each
0021993	ToyoScreen Q-600C AR	5 mL × 6 each
0021366	ToyoScreen CM-650M	1 mL × 6 each
0021367	ToyoScreen CM-650M	5 mL × 6 each
0021951	ToyoScreen GigaCap CM-650M	1 mL × 6 each
0021952	ToyoScreen GigaCap CM-650M	5 mL × 6 each
0021368	ToyoScreen SP-650M	1 mL × 6 each
0021369	ToyoScreen SP-650M	5 mL × 6 each
0021370	ToyoScreen SP-550C	1 mL × 6 each
0021371	ToyoScreen SP-550C	5 mL × 6 each
0021870	ToyoScreen MegaCap II SP-550EC	1 mL × 6 each
0021871	ToyoScreen MegaCap II SP-550EC	5 mL × 6 each
0021868	ToyoScreen GigaCap S-650M	1 mL × 6 each
0021869	ToyoScreen GigaCap S-650M	5 mL × 6 each
0021372	ToyoScreen Ether-650M	1 mL × 6 each
0021373	ToyoScreen Ether-650M	5 mL × 6 each
0021374	ToyoScreen Phenyl-650M	1 mL × 6 each
0021375	ToyoScreen Phenyl-650M	5 mL × 6 each
0021376	ToyoScreen Butyl-650M	1 mL × 6 each
0021377	ToyoScreen Butyl-650M	5 mL × 6 each
0021378	ToyoScreen Hexyl-650C	1 mL × 6 each
0021379	ToyoScreen Hexyl-650C	5 mL × 6 each
0021380	ToyoScreen PPG-600M	1 mL × 6 each
0021381	ToyoScreen PPG-600M	5 mL × 6 each
0021494	ToyoScreen Butyl-600M	1 mL × 6 each
0021495	ToyoScreen Butyl-600M	5 mL × 6 each
0021892	ToyoScreen Phenyl-600M	1 mL × 6 each
0021893	ToyoScreen Phenyl-600M	5 mL × 6 each
0021382	ToyoScreen SuperButyl-550C	1 mL × 6 each
0021383	ToyoScreen SuperButyl-550C	5 mL × 6 each
0021384	ToyoScreen AF-Chelate-650M	1 mL × 6 each
0021385	ToyoScreen AF-Chelate-650M	5 mL × 6 each
0021386	ToyoScreen AF-Blue HC-650M	1 mL × 6 each
0021387	ToyoScreen AF-Blue HC-650M	5 mL × 6 each
0021388	ToyoScreen AF-Red-650M	1 mL × 6 each
0021389	ToyoScreen AF-Red-650M	5 mL × 6 each
0021390	ToyoScreen AF-Heparin HC-650M	1 mL × 6 each
0021391	ToyoScreen AF-Heparin HC-650M	5 mL × 6 each
0022809	ToyoScreen AF-rProtein A-650F	1 mL × 5 each
0022810	ToyoScreen AF-rProtein A-650F	5 mL × 1 each
0022811	ToyoScreen AF-rProtein A-650F	5 mL × 5 each
0022824	ToyoScreen MX-Trp-650M	1 mL × 6 each
0022825	ToyoScreen MX-Trp-650M	5 mL × 6 each
0022872	ToyoScreen GigaCap DEAE-650M	1 mL × 6 each
0022873	ToyoScreen GigaCap DEAE-650M	5 mL × 6 each

Part No.	Product Description	Package
0023436	ToyoScreen AF-rProtein A HC-650F	1 mL × 1 each
0023430	ToyoScreen AF-rProtein A HC-650F	1 mL × 5 each
0023431	ToyoScreen AF-rProtein A HC-650F	5 mL × 1 each
0023432	ToyoScreen AF-rProtein A HC-650F	5 mL × 5 each
0021392	ToyoScreen A-IEC (DEAE-650M, SuperQ-650M, QAE-550C, GigaCap Q-650M, Q-600C AR)	1 mL × 5 Grades × 1 each
0021393	ToyoScreen A-IEC (DEAE-650M, SuperQ-650M, QAE-550C, GigaCap Q-650M, Q-600C AR)	5 mL × 5 Grades × 1 each
0021394	ToyoScreen C-IEC (CM-650M, SP-650M, SP-550C, GigaCap CM-650M, GigaCap S-650M)	1 mL × 5 Grades × 1 each
0021395	ToyoScreen C-IEC (CM-650M, SP-650M, SP-550C, GigaCap CM-650M, GigaCap S-650M)	5 mL × 5 Grades × 1 each
0021396	ToyoScreen IEC (GigaCap Q-650M, SuperQ-650M, Q-600C AR, GigaCap CM-650M, GigaCap S-650M, SP-550C)	1 mL × 6 Grades × 1 each
0021397	ToyoScreen IEC (GigaCap Q-650M, SuperQ-650M, Q-600C AR, GigaCap CM-650M, GigaCap S-650M, SP-550C)	5 mL × 6 Grades × 1 each
0021398	ToyoScreen HIC (PPG-600M, Butyl-600M, Phenyl-650M, Butyl-650M, Phenyl-600M, Hexyl-650C)	1 mL × 6 Grades × 1 each
0021399	ToyoScreen HIC (PPG-600M, Butyl-600M, Phenyl-650M, Butyl-650M, Phenyl-600M, Hexyl-650C)	5 mL × 6 Grades × 1 each
0021400	ToyoScreen Holder	Column holder body × 1 each, Inlet cap (male end) × 1 each (for 1 mL column), Inlet cap (male end) × 1 each (for 5 mL column), Outlet cap (female end) × 1 each (for 1 mL and 5 mL column), Screws plug × 2 each



TOSOH

TOSOH CORPORATION

BIOSCIENCE DIVISION

Shiba-Koen First Bldg.
3-8-2 Shiba, Minato-ku, Tokyo 105-8623, Japan
Phone: +81-3-5427-5180 Fax: +81-3-5427-5220
Web site: <http://www.separations.asia.tosohbioscience.com/>
HPLC database: www2.tosoh.co.jp/hlc/hlcdb.nsf/StartE?OpenForm

TOSOH BIOSCIENCE LLC

3604 Horizon Drive Suite 100,
King of Prussia, PA 19406, USA
Phone: +1-800-366-4875 Fax: +1-610-272-3028
E-mail: info.tbl@tosoh.com
Web site: <http://www.tosohbioscience.com/>

TOSOH BIOSCIENCE GmbH

Zettachring 6, 70567 Stuttgart, Germany
Phone: +49-711-132570 Fax: +49-711-1325789
E-mail: info.tb@tosoh.com
Web site: <http://www.tosohbioscience.com/>

TOSOH BIOSCIENCE SHANGHAI CO., LTD.

Room 301, Plaza B, No.1289 Yi Shan Road,
Xu Hui District, Shanghai 200233, China
Phone: +86-21-3461-0856 Fax: +86-21-3461-0858
E-mail: info@tosoh.com.cn
Web site: <http://www.separations.asia.tosohbioscience.com/>

TOSOH ASIA PTE. LTD.

63 Market Street #10-03 Singapore 048942
Phone: +65-6226-5106 Fax: +65-6226-5215
E-mail: info.tsas@tosoh.com
Web site: <http://www.separations.asia.tosohbioscience.com/>

TSKgel, TSKgel SuperMultipore, TSKgel STAT, BioAssist, Lipopropak, TOYOPEARL, ToyoScreen, TOYOPEARL GigaCap, TOYOPEARL MegaCap, TOYOPAK and EcoSEC are registered trademarks of Tosoh Corporation in Japan, United States, European Union, etc.

HLC is the registered trademark of Tosoh Corporation in Japan and China.

This manual may not be reprinted or copied in whole or in part without written consent of Tosoh Corporation.
The contents of the manual are subject to change without notice.

Printed in Japan